

Multimatic™ 200

Issued February 2013 • Index No. DC/12.57

**MIG/Multiprocess Power Source,
Wire Feeder and Gun Package**



Quick Specs

Light Industrial Applications

Light Fabrication
Maintenance and Repair
Mechanical Contractor
Construction

Processes

MIG (GMAW)
Flux-Cored (FCAW)
DC TIG (GTAW)
DC Stick (SMAW)

Weld Thickness

MIG welds 24 ga.–3/8 in. mild steel and 18 ga.–1/4 in. aluminum.
TIG welds .020–3/16 in. mild steel

Input Power

120 V, 20 A, 50/60 Hz, single phase
230 V, 18 A, 50/60 Hz, single phase

Weight 29 lb. (13.2 kg)

The Power of Blue.®

The only all-in-one, portable, multiprocess power source from Miller is our most versatile machine to date. Weighing only 29 pounds (13.2 kg) and running on either 120 or 230 V, the Multimatic 200 can go anywhere you need to MIG, TIG or Stick weld.

NEW! Auto-Set™ Elite can be used on multiple materials and multiple processes with the ability to fine-tune your settings. Simple to set up and use!

Impact-resistant case provides strength and durability, protecting the internal components and welding wire.

Excellent arc characteristics! Multimatic 200 offers positive arc starts and an extremely stable arc with minimal spatter on both mixed gases and straight CO₂.

Multi-voltage plug (MVP™) allows you to connect to common 120 or 230 V power receptacles without the use of any tools—choose the plug that fits the receptacle and connect it to the power cord.



New!

Comes complete with:

- Power source
- Power cord and MVP plugs for 120 and 230 V
- 10-ft. (3 m) Bernard® Q150 MIG gun
- 13-ft. (4 m) lead with electrode holder and 25-mm Dinse connector
- 10-ft. (3 m) work lead with clamp and 25-mm Dinse connector
- Two contact tips for .030-in. (0.8 mm) wire, and two contact tips for .035-in. (0.9 mm) wire
- Dual-groove quick-change drive rolls for .024-in. (0.6 mm) or .030/.035-in. (0.8/0.9 mm) wire
- Smith® Argon and AR/CO₂ mix regulator/flow gauge with 12-ft. (3.7 m) hose
- Setup and operation DVD
- Information/settings chart and quick setup guide
- Material thickness gauge ▶ #229 895

Note: Shielding gas and safety equipment not included.

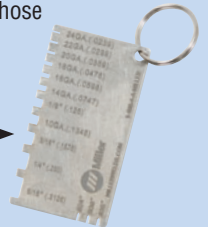

Optional Spoolmate™

100 direct-connect spool gun offers a reliable and economical solution for welding aluminum up to 1/4 inch with 4043 aluminum wire.



Optional TIG Contractor Kit gives you everything you need for remote TIG welding with the Multimatic 200.



TRUE BLUE
3 YR. WARRANTY

Welder is warranted for 3 years, parts and labor.
Gun warranted for 6 months, parts and labor.



Miller Electric Mfg. Co.
An Illinois Tool Works Company
1635 West Spencer Street
Appleton, WI 54914 USA

Equipment Sales US and Canada
Phone: 866-931-9730
FAX: 800-637-2315
International Phone: 920-735-4554
International FAX: 920-735-4125

Website
MillerWelds.com



Specifications (Subject to change without notice.)



Welding Mode/ Process	Input Power	Welding Amperage Range	Rated Output	Amps Input at Rated Output, 50/60 Hz 120 V 230 V KVA KW	Wire Feed Speed	Max. Open-Circuit Voltage	Dimensions	Weight
CV: MIG/ Flux-Cored	120/230 VAC	30–140 A	90 A at 18.5 V, 60% Duty Cycle	18 — 2.2 2	70–425 IPM (1.8–10.8 m/min.)	90	H: 14.5 in. (368 mm) W: 9.75 in. (248 mm) D: 17 in. (432 mm)	29 lb. (13.2 kg)
		30–140 A	110 A at 19.5 V, 20% Duty Cycle	20 — 2.7 2.6				
		30–200 A	150 A at 21.5 V, 20% Duty Cycle	— 17.5 4.0 3.8				
CC: TIG	120 VAC	5–150 A	100 A at 14 V, 100% Duty Cycle	15.8 — 1.9 1.8	—	90 VDC (22–25 VDC*)		
			150 A at 16 V, 30% Duty Cycle	27 — 3.3 3.2				
	230 VAC	5–150 A	100 A at 14 V, 100% Duty Cycle	— 8 1.9 1.7				
			150 A at 16 V, 30% Duty Cycle	— 13.8 3.2 3.0				
CC: Stick	120 VAC	20–150 A	70 A at 22.8 V, 100% Duty Cycle	16.5 — 2.0 1.9				
			100 A at 24 V, 35% Duty Cycle	24 — 2.9 2.8				
	230 VAC	20–150 A	100 A at 24 V, 100% Duty Cycle	— 12.7 2.9 2.7				
150 A at 26 V, 30% Duty Cycle			— 20.8 4.8 4.5					

*Sense voltage for Stick and Lift-Arc™ TIG.

Certified by Canadian Standards Association to both the Canadian and U.S. Standards.

Control Panel

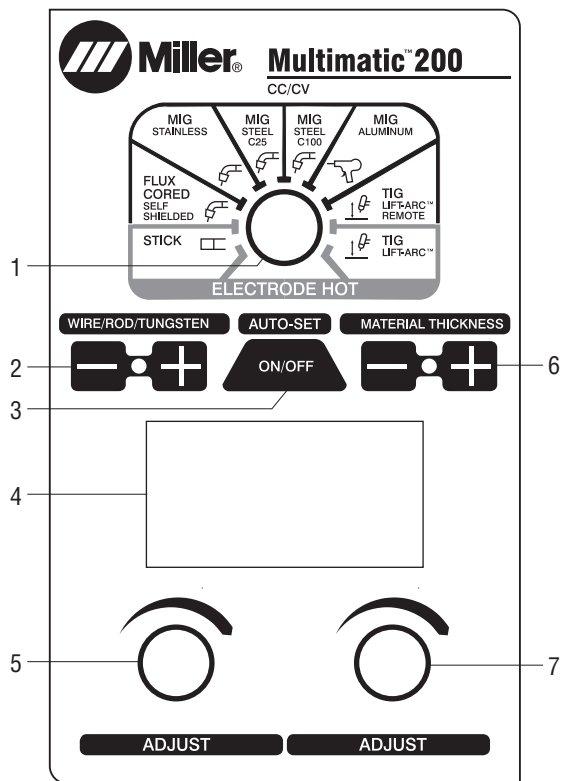

1. Process Selection Knob
2. Wire/Tungsten Diameter and Stick Rod Type Buttons
3. Auto-Set Button
4. LCD Display Panel
5. Adjustment Knob
6. Material Thickness Buttons
7. Adjustment Knob

Performance Data

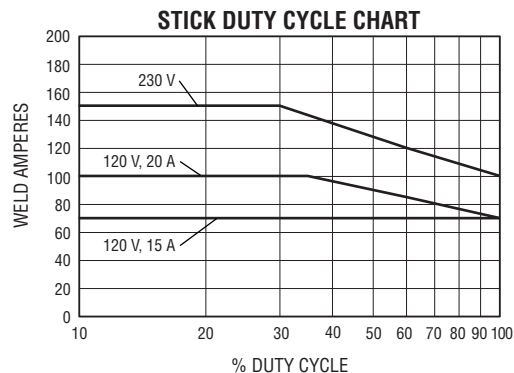
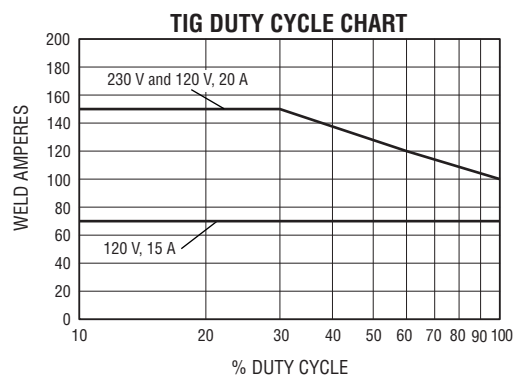
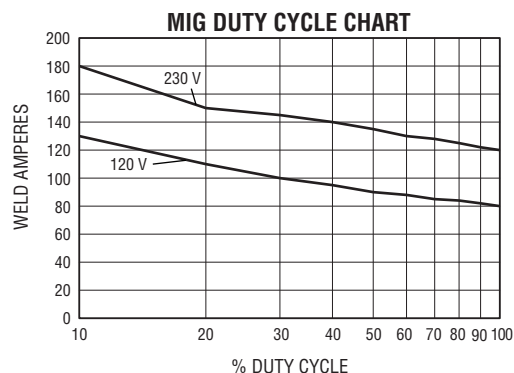

Genuine Miller® Accessories



Spoolmate™ 100 Series Spool Gun #300 371

Direct-connect spool gun for Multimatic 200 and all Millermatic

140, 180, 211 and Passport Plus models. Handles .030–.035 inch (0.8–0.9 mm) aluminum (4043 only) and .023–.035 inch (0.6–0.9 mm) steel/stainless steel wires. Rated at 135 amps, 30 percent duty cycle. Includes 12-foot (3.7 m) cable assembly and custom carrying case.

Bernard® Q150 Replacement Gun #1510AB8BM 10 ft. (3 m)



TIG Contractor Kit #300 851

Kits comes complete with everything needed to TIG weld with the Multimatic® 200. Includes Weldcraft® 150-amp LS17 TIG torch with 25-mm Dinse connector and integrated 6-pin north/south fingertip controls, an AK-2C torch accessory kit, regulator, gas hose, and a protective carrying case to store all your cables and leads in the field.



14-Pin to 6-Pin Adapter Cord #300 507

Adapts Miller 14-pin foot control or fingertip control to a 6-pin plug.



Running Gear/Cylinder Rack #770 187

Heavy-duty construction. Convenient handle on front with cable holders. For gas cylinders no larger than 7 inches (178 mm) in diameter. Maximum weight is 100 pounds (45 kg).



RFCS-6M Remote Foot Control #195 183

Foot pedal current and contactor control. Includes 13.25-foot (4 m) cord and 6-pin plug.



Small Running Gear/Cylinder Rack #300 425

Durable construction. For gas cylinders no larger than 7 inches (178 mm) in diameter. Maximum weight is 75 pounds (34 kg).

Consumables (Order from Miller Service Parts.)

For Q150 Gun

Insulator Cap 4323R

Gas Diffuser DS-1



Contact Tips

T-023 .024 in. (0.6 mm)

T-030 .030 in. (0.8 mm)

T-035 .035 in. (0.9 mm)



Replacement Liners

#194 010 .024 in.

#194 011 .030–.035 in. (standard)

#194 012 .035–.045 in.

Liners are 15-foot lengths – trim to size needed.



Nozzle NS-1200B

Self-Shielded Conversion Kit NS-FLX

Consists of tip holder 7010046, and insulators 7010024 and 7010059.



Drive Rolls — Quick Change

Dual Groove, V-Smooth #220 179

For .024-inch (0.6 mm) or .030/.035-inch (0.8/0.9 mm) wire.

Dual Groove, V-Knurled #202 926

For .030/.035-inch (0.8/0.9 mm) or .045-inch (1.2 mm) flux-cored wire.

For Spoolmate™ 100 Series



Contact Tips (5 per package)

#199 730 For .024-inch (0.6 mm) wire.

#186 419 For .030-inch (0.8 mm) wire.

#186 406 For .035-inch (0.9 mm) wire.



Nozzle #186 405



Drive Roll (1)

#186 413

For .030/.035-inch (0.8/0.9 mm) wire.



Push Roll (1)

#186 414

For .030/.035-inch (0.8/0.9 mm) wire.

Ordering Information

Power Source and Options	Stock No.	Description	Qty.	Price
Multimatic™ 200 with Auto-Set™ Elite	#907 518	120/230 VAC, 50/60 Hz		
Multimatic™ 200 with Auto-Set™ Elite and TIG Contractor Kit	#951 474	Power source packaged with #300 851 TIG Contractor Kit		
Guns				
Spoolmate™ 100 Series Spool Gun	#300 371	12 ft. (3.7 m). Includes custom carrying case		
Bernard® Q150 MIG Gun	Q1510AB8BM	10 ft. (3 m)		
Accessories				
TIG Contractor Kit	#300 851	Includes Weldcraft® 150-amp LS17 TIG torch with 25-mm Dinse connector and integrated fingertip control, AK-2C torch accessory kit, regulator, gas hose, and carrying case		
RFCS-6M Remote Foot Control	#195 183	13.25-ft. (4 m) cord and 6-pin plug		
14-Pin to 6-Pin Adapter Cord	#300 507	Adapts Miller® 14-pin foot control or fingertip control to a 6-pin plug		
Running Gear/Cylinder Rack	#770 187			
Small Running Gear/Cylinder Rack	#300 425			
CO ₂ Regulator/Flow Gauge	#237 702	Required if using 100% CO ₂ Gas. <i>Order from Miller Service Parts</i>		
Material Thickness Gauge	#229 895			
Flux-Cored Wire				
Solid Wire				
Shielding Gas Cylinder				
Helmet/Gloves/Scratch Brush				
Available Through Service Parts				
MVP™ Adapter 115 V 5-20P	#219 259	Used to connect power source to 5-20R receptacle (not included with machine)		
MVP™ Adapter 115 V 5-15P	#219 261	Used to connect power source to 5-15R receptacle (included with machine)		
MVP™ Adapter 230 V 6-50P	#219 258	Used to connect power source to 6-50R receptacle (included with machine)		
Replacement Screen Cover	#231 410	Snap-in replacement cover for LCD screen		
Insulator Cap	4323R			
Gas Diffuser	DS-1			
Contact Tips		See page 3		
Replacement Liners		See page 3		
Nozzles		See page 3		
Self-Shielded Conversion Kit	NS-FLX	Consists of tip holder 7010046, and insulators 7010024 and 7010059		
Drive Rolls		See page 3		

Date:

Total Quoted Price:



Distributed by: