

# Big Blue® 500 X and 600 X

Issued June 2012 • Index No. EDX/10.11

Engine-Driven  
Welder/Generator 

## Quick Specs



### Heavy Industrial Applications

Heavy Construction  
Structural Steel  
Maintenance and Repair Rigs  
Mining Maintenance  
Process Piping  
Sheet Metal

### Processes

Stick (SMAW)  
MIG (GMAW)  
Flux-Cored (FCAW)  
DC TIG (GTAW)  
Submerged Arc (SAW)  
Stud Welding  
Air Carbon Arc (CAC-A)  
**500 X:**  
Rated: 8-mm (5/16 in.) carbons  
Capable: 9.5-mm (3/8 in.) carbons  
**600 X:**  
Rated: 9.5-mm (3/8 in.) carbons

### Output Range

**500 X CC:** DC Stick 55–500 A DC/TIG 55–500 A  
**500 X CC/CV:** DC Stick 40–550 A DC/TIG 15–350 A  
MIG/FCAW 14–40 V  
**600 X CC:** DC Stick 55–600 A DC/TIG 55–600 A  
**600 X CC/CV:** DC Stick 40–600 A DC/TIG 20–425 A  
MIG/FCAW 14–40 V

### Generator Output Rated at 40°C (104°F)

5500 Watts Peak — 4000 Watts Continuous

**Accu-Rated™ — Not Inflated  
Generator Power**

## The Power of Blue.®

**Designed for fleet owners** that demand the ultimate in reliability and performance.

**Three-phase rotating field generator** efficiently produces smooth DC weld output using 20–30 percent less fuel than a rotating armature-type DC generator.

**Enclosed robust case design** protects internal components from impact and allows air flow to cool and prolong the life of the engine. Also reduces sound levels.

**Quick and easy maintenance** with single-side access to oil level check, oil fill, oil filter, fuel filter and air cleaner.

**Remote toolless oil drain** allows oil to be drained without getting under the engine and reduces the chance of oil spillage.



**CC/CV Models: The Vault** — ultimate control board reliability. See page 3.



**Heavy-duty low-speed industrial diesel engines** are designed, built and proven to operate over 10,000 hours before the first basic overhaul.

### Meter maintenance displays

- Fuel gauge
- Hour meter function
- Oil change interval
- High coolant temperature and low oil pressure shutdowns
- Low fuel shutdown — engine shuts down before system runs out of fuel, making restarts easy.

**Hot Start™** provides positive Stick electrode starts making it easy to start all types of electrodes and it also works great for bead tie-ins.

**Arc-Drive™** makes welding easy. Automatically enhances Stick welding, especially on pipe, by focusing the arc and preventing the electrode from going out.

**Weatherproof Lexan® nameplate** resists cracking and fading, and is color-coded for ease of operation.

**GFCI receptacle** as required on most jobsites to protect operators from electrical hazards.

**CSA, IEC and NEMA compliant for welders.** Degree of protection provided by enclosure IP23.



Big Blue 600 X CC shown.



Welder/generator is warranted by Miller for 3 years, parts and labor.  
Engine is warranted separately by engine manufacturer.



**Miller Electric Mfg. Co.**  
An Illinois Tool Works Company  
1635 West Spencer Street  
Appleton, WI 54914 USA

**Equipment Sales US and Canada**  
Phone: 866-931-9730  
FAX: 800-637-2315  
International Phone: 920-735-4554  
International FAX: 920-735-4125

**Website**  
MillerWelds.com



# Big Blue® 500 X and 600 X CC Specifications (Subject to change without notice.)



Model	Welding Mode/Process	Weld Output Range	Weld Output Rated at 40° C (104° F)	Max. Open-Circuit Voltage	Generator Output Rated at 40° C (104° F)	Dimensions**	Weight (without fuel)***
Big Blue 500 X CC	CC/DC (Stick/TIG)	55–500 A	400 A at 36 V (14.4 kW),* 100% Duty Cycle 450 A at 38 V (17.1 kW),* 60% Duty Cycle 500 A at 30 V (15 kW), 40% Duty Cycle	95	<b>Peak:</b> 5500 watts <b>Continuous:</b> 4000 watts, 1-phase, 34/17 A, 120/240 VAC, 50/60 Hz while welding	H: 1092 mm (43 in.) W: 724 mm (28.5 in.) D: 1654 mm (65.125 in.)	<b>Perkins 404D.22:</b> 701 kg (1545 lb.) <b>Deutz D2011L03i:</b> 751 kg (1655 lb.)
Big Blue 600 X CC	CC/DC (Stick/TIG)	55–600 A	500 A at 40 V (20 kW),* 100% Duty Cycle 550 A at 34 V (18.7 kW), 60% Duty Cycle 600 A at 30 V (18 kW), 40% Duty Cycle				<b>Deutz D2011L04i:</b> 769 kg (1695 lb.) <b>Deutz D912L03:</b> 810 kg (1785 lb.)

\*Perkins powered models are **CE** approved — meet NEMA and IEC output ratings. Deutz powered models meet NEMA and IEC output ratings.

\*\*Additional 178 mm (7 in.) to top of exhaust. \*\*\*Additional 86 kg (190 lb.) when fuel tank is full.

## Big Blue® 500 X and 600 X CC Control Panel

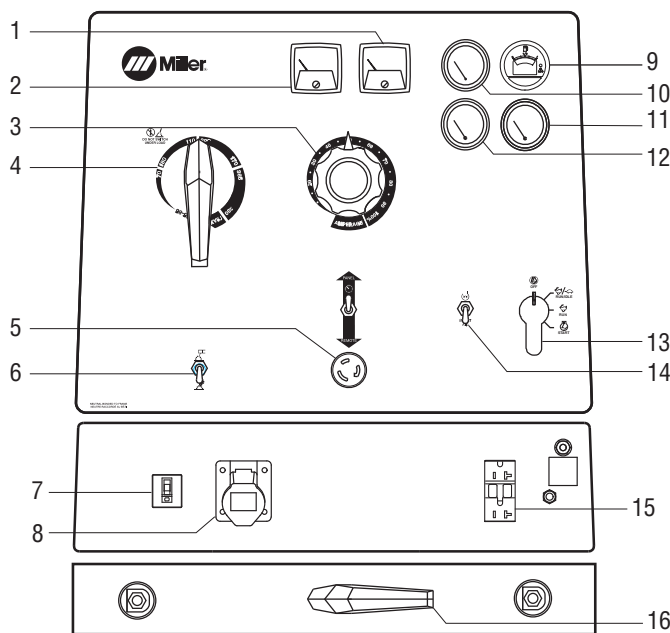

1. DC Ammeter\*
  2. DC Voltmeter\*
  3. Amperage Adjust Control
  4. Amperage Range Switch
  5. Amperage Adjust Switch and Remote Amperage Adjust Receptacle
  6. Stick/TIG Selector Switch
  7. Earth Leakage Circuit Breaker
  8. 230 VAC, 16 A Pin and Sleeve Receptacle
  9. Fuel Gauge/Hour Meter/Oil Change Interval/Engine Shutdown Indicator
  10. Engine Oil Pressure Gauge
  11. Battery/Voltmeter\*
  12. Engine Coolant Temperature Gauge
  13. Engine Control Switch
  14. Starting Aid Switch (standard on Perkins model)
  15. 120 VAC, 20 A GFCI Duplex Receptacle
  16. Polarity Switch\*
- \*Optional.

### Additional Features

**Proven, rugged rheostat control technology** that has been in Miller engine drives for over 60 years. Contains no printed control boards.

A **Stick/TIG switch** optimizes open-circuit voltage for Stick welding and allows the open-circuit voltage to be lowered for scratch start TIG welding.

Provisions are provided to plug a **RHC3GD34A remote control** that will allow precise adjustment of amperage without walking back to the machine.

# Big Blue® 500 X and 600 X CC/CV Specifications (Subject to change without notice.)



Model	Welding Mode/Process	Weld Output Range	Weld Output Rated at 40°C (104°F)	Max. Open-Circuit Voltage	Generator Output Rated at 40°C (104°F)	Dimensions**	Weight (without fuel)***
Big Blue 500 X CC/CV	CC/DC (Stick/TIG)	15–500 A	400 A at 36 V (14.4 kW),* 100% Duty Cycle 450 A at 38 V (17.1 kW),* 60% Duty Cycle	95	Peak: 5500 watts Continuous: 4000 watts, 1-phase, 34/17 A, 120/240 VAC, 50/60 Hz while welding	H: 1092 mm (43 in.) W: 724 mm (28.5 in.) D: 1654 mm (65.125 in.)	Perkins 404D.22: 701 kg (1545 lb.) Deutz D2011L03i: 751 kg (1655 lb.)
	CV/DC (MIG/FCAW)	14–40 V	500 A at 34 V (17 kW), 40% Duty Cycle				
Big Blue 600 X CC/CV	CC/DC (Stick/TIG)	20–600 A	500 A at 40 V (20 kW),* 100% Duty Cycle 550 A at 42 V (23.1 kW), 60% Duty Cycle	95	Peak: 5500 watts Continuous: 4000 watts, 1-phase, 34/17 A, 120/240 VAC, 50/60 Hz while welding	H: 1092 mm (43 in.) W: 724 mm (28.5 in.) D: 1654 mm (65.125 in.)	Deutz D2011L04i: 769 kg (1695 lb.) Deutz D912L03: 810 kg (1785 lb.)
	CV/DC (MIG/FCAW)	14–40 V	600 A at 34 V (20.4 kW), 40% Duty Cycle				

\*Perkins powered models are approved — meet NEMA and IEC output ratings. Deutz powered models meet NEMA and IEC output ratings.

\*\*Additional 178 mm (7 in.) to top of exhaust. \*\*\*Additional 86 kg (190 lb.) when fuel tank is full.

## Big Blue® 500 X and 600 X CC/CV Control Panel

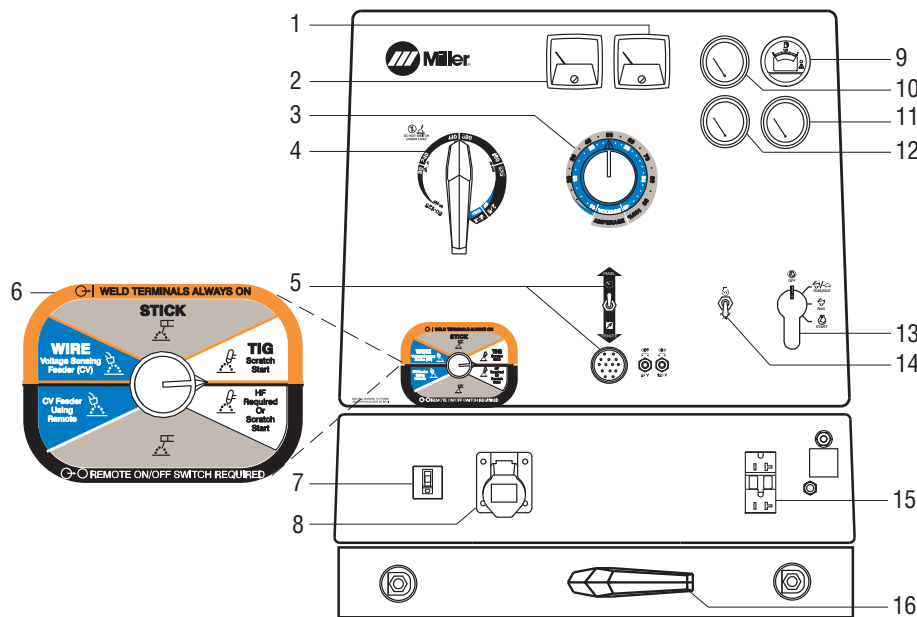

1. DC Ammeter
2. DC Voltmeter
3. Amperage/Voltage Adjust Control
4. Amperage Range Switch
5. Amperage/Voltage Adjust Switch and Remote Amperage/Voltage Adjust Receptacle
6. Process/Contactor Selector Switch
7. Earth Leakage Circuit Breaker
8. 230 VAC, 16 A Pin and Sleeve Receptacle
9. Fuel Gauge/Hour Meter/Oil Change Interval Engine Shutdown Indicator
10. Engine Oil Pressure Gauge
11. Battery/Voltmeter\*
12. Engine Coolant Temperature Gauge
13. Engine Control Switch
14. Starting Aid Switch (standard on Perkins model)
15. 120 VAC, 20 A GFCI Duplex Receptacle
16. Polarity Switch\*

\*Optional.

### Additional Features

**One MIG welding range** allows precise voltage control for welding with 0.6–3.2 mm (.023–.120 in.) wires.

A multi-colored **process selector control** allows quick and easy process changes without having to use multiple switches.

**14-pin remote control** allows precise adjustment of amperage or voltage, along with contactor control, without walking back to the machine.

**The Vault — Superior Circuit Board Design**  
Our critical circuit boards are engineered to carry *low power* and *low heat* to reduce thermal stress and minimize expansion and contraction. In contrast, our competitor's

boards carry *high power* and *high heat*, them more vulnerable to failure.

#### “The Vault” Makes Upgrading to Miller® CC/CV Units Worry-Free

Concerns with circuit board reliability have resulted in some operators steering clear of CC/CV welder/generators — even though they offer a superior arc and multiple welding processes. Miller circuit board reliability isn't a concern since all Big Blue multiprocess industrial engine drives feature the Vault.

Created out of two aluminum halves sealed with silicone, as well as watertight harness connections, the Vault provides a clean circuit board environment, protecting the electronics —



and controlling output — in heavy industrial applications. No other competitor protects their electronics with a sealed vault, leaving critical circuit boards exposed to harsh elements that can disrupt the machine's electronics, and therefore, its operation.

# Big Blue® 500 X and 600 X CC Performance Data

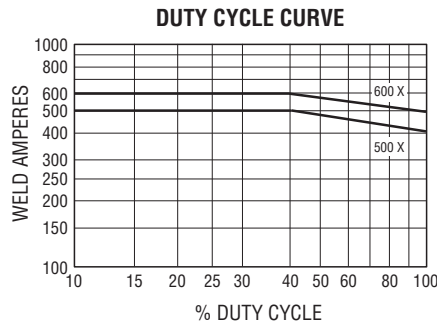
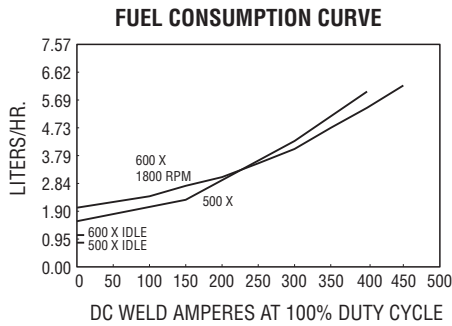
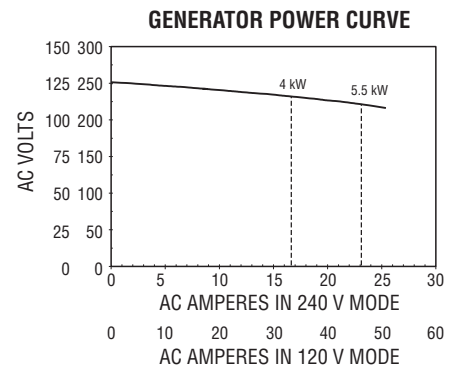
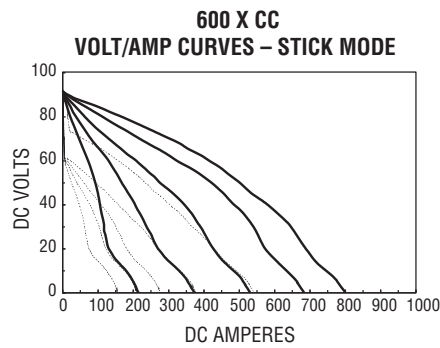
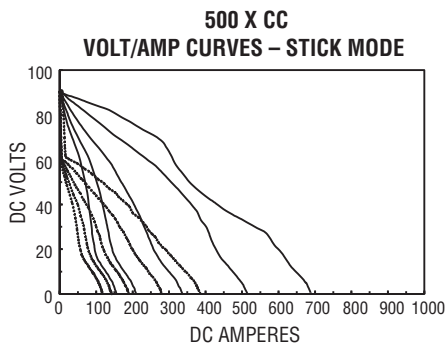

# Big Blue® 500 X and 600 X CC/CV Performance Data

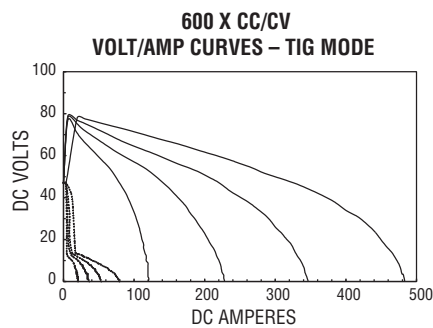
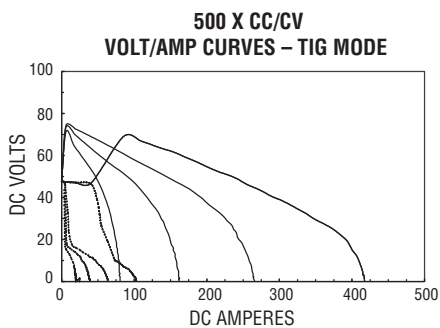
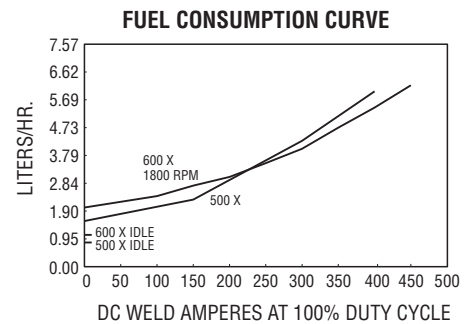
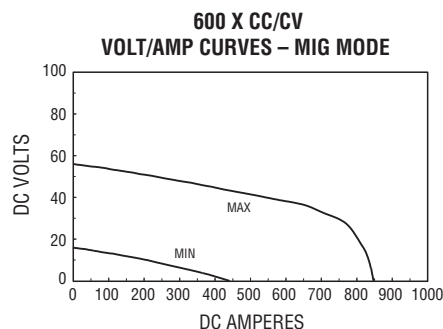
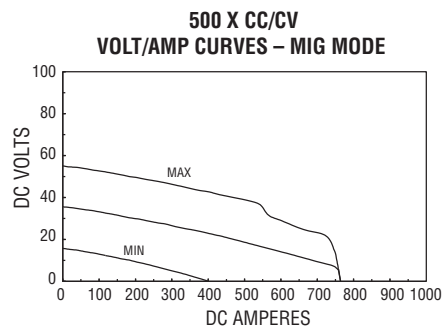
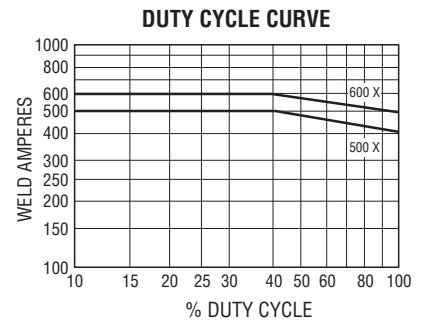
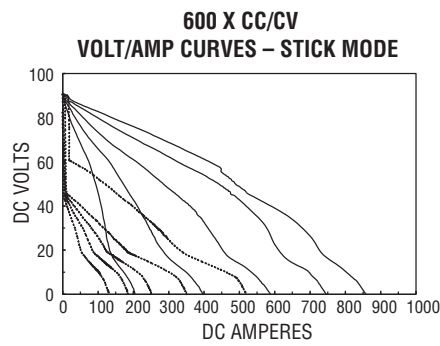
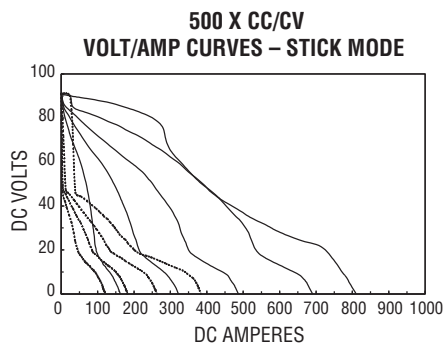

## Engine Specifications (Subject to change without notice.)

Model	Engine Brand	Features	HP	Type	Engine Speeds (RPM)	Capacities	Automatic Engine Shutdowns
Big Blue 500 X	Perkins 404D.22	EPA Tier 4i compliant, indirect-injected, liquid-cooled engine with full load <b>sound levels of 73.2 dB @ 7 m (98 Lwa)</b> . Right-side service access with intervals of <b>500 hours</b> for <b>oil and filters</b> .	32.6	4-cylinder, industrial, liquid-cooled diesel	Weld: 1850	Fuel: 95 L (25 gal.) Oil: 8.5 L (9 qt.) Coolant: 8.5 L (9 qt.)	Low Oil Pressure, High Coolant Temperature, Low Fuel Level
	Deutz D2011L03i	EPA Tier 4i compliant, direct-injected, air/oil-cooled engine with full load <b>sound levels of 76.8 dB @ 7 m (101.7 Lwa)</b> . Right-side service access with intervals of <b>1000 hours</b> for <b>oil and filters</b> . Approved <b>underground</b> operation with the purchase of a <b>MSHA</b> (30 CFR part 7) certificate.	32.0	3-cylinder, industrial, air/oil-cooled diesel	Weld: 1850	Fuel: 95 L (25 gal.) Oil: 5.9 L (6.2 qt.) Coolant: Integrated oil	Low Oil Pressure, High Coolant Temperature, Low Fuel Level
Big Blue 600 X	Deutz D2011L04i	EPA Tier 4i compliant, direct-injected, air/oil-cooled engine with full load <b>sound levels of 76 dB @ 7 m (101 Lwa)</b> . Right-side service access with intervals of <b>1000 hours</b> for <b>oil and filters</b> .	48.6	4-cylinder, industrial, air/oil-cooled diesel	Weld: 1850	Fuel: 95 L (25 gal.) Oil: 8.5 L (9 qt.) Coolant: Integrated oil	Low Oil Pressure, High Coolant Temperature, Low Fuel Level
	Deutz D912L03	The legendary Tier I, EPA-certified, direct-injected, air-cooled engine with full load <b>sound levels of 81 dB @ 7 m (106 Lwa)</b> . Right-side service access with intervals of <b>500 hours</b> for <b>oil and filters</b> .	41.5	3-cylinder, industrial, air-cooled diesel	Weld: 1850	Fuel: 95 L (25 gal.) Oil: 8.5 L (9 qt.) Coolant: Air	Low Oil Pressure, High Coolant Temperature, Low Fuel Level

## Genuine Miller® Options

### Weld Ammeter and Voltmeter Kit

#195 131 Field

Panel-mounted analog meters monitor welding output.

Installation time: 35 minutes

### Polarity Reversing Switch Kit

#043 942 Field

Changes DC polarity without the use of tools.

Installation time: 35 minutes

### AC/DC Polarity Reversing Switch Kit

#195 095 Field

Select AC output or DC polarity without the use of tools.

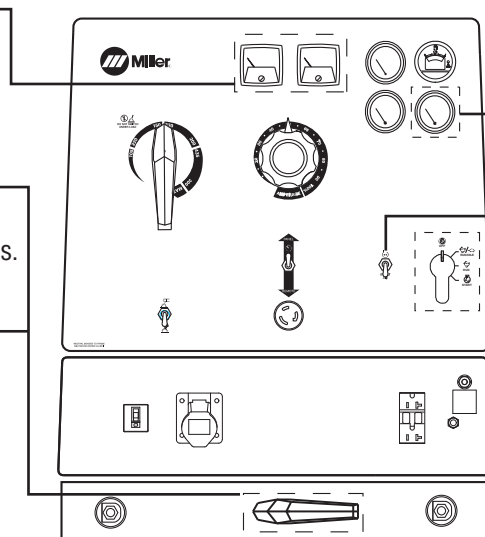

### Battery Voltmeter

#195 454 Field

Monitors battery-charging circuit.

### Cold Weather Starting Aid Kit

Note: Perkins 404D.22 models come standard with glow plugs.

#195 056 Field

Perkins. 120 V block heater.

#195 307 Field

Deutz D2011L03i/ D2011L04i. 12 V intake manifold heater.

#195 086 Field

Deutz D2011L03i/ D2011L04i. 120 V oil pan heater.

# Genuine Miller® Accessories



**International Plug**  
#255 416 Field  
1-Phase, 240 VAC, 16 A plug

## Engine Filter Kits

#246 988 Field. For Deutz D2011  
#246 989 Field. For Deutz D912  
#246 985 Field. For Perkins 404  
Includes all filters required for proper engine maintenance. Oil filter, primary and secondary fuel filter, and primary air filter.

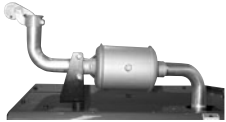

**Spark Arrestor Muffler Kit**  
#195 012 Field  
Prevents particles

from leaving the muffler that could potentially start a fire. Mandatory when operating on California grasslands, brush, or forest-covered land, and in all National Forests. For other areas, check your state and local laws. Meets US Forest Service standard 5100-1B.



**FA-1D Lockable Flame Arrestor Fuel Cap** #043 947 Field  
Fuel cap can be padlocked to prevent vandalism. A built-in flame arrestor prevents flames or sparks from entering the fuel tank.



**Vandalism Lockout Kit**  
#195 118 Field  
Lockable hinged steel panels cover and protect name plate gauges and ignition switch (padlock included). Also includes engine compartment door lock and key.



**Cable Holder**  
#043 946 Field  
Saddle-bag-style cable holder. Convenient wrap-around storage of coiled cable for transportation. Stores 30.5 m of 2/0 cable on each side.

*Note: For best results do not weld when cable is coiled! Protective cover cannot be used with cable holder.*



**Protective Cover**  
#194 683 Field  
Blue water-resistant canvas cover resists stains and mildew, and protects the finish of your welder.

*Note: Protective cover cannot be used with cable holder.*

## Stick (SMAW) Welding

**Weld Leads**  
**2/0 Stick Cable Set, 15 m (50 ft.)**  
#173 851

Consists of 15-m (50 ft.) 2/0 electrode cable with holder, and 15-m (50 ft.) work cable with clamp. 350 A, 100% duty cycle.

**2/0 Stick Cable Set, 30.5/15 m (100/50 ft.)**  
#043 952

Consists of 30.5-m (100 ft.) 2/0 electrode cable with holder, and 15-m (50 ft.) work cable with clamp. 300 A, 100% duty cycle.

## MIG (GMAW) or Flux-Cored (FCAW)



**SuitCase® X-TREME™ 8VS Wire Feeder**  
#300 656

**SuitCase® X-TREME™ 12VS Wire Feeder**  
#300 659

Lightweight, voltage-sensing wire feeders include secondary contactor and gas valve. Requires drive roll kit. See Lit. Index No. M/6.41.



**SuitCase® 8RC Wire Feeder** #300 660  
**SuitCase® 12RC Wire Feeder** #300 663

Lightweight and flexible enough to run a variety of wires up to 1.6-mm diameter. Includes remote voltage control. Requires drive roll kit. See Lit. Index No. M/6.5.

**MIG (GMAW)/Flux-Cored (FCAW) Guns**  
Miller produces a complete line of dependable MIG guns. See Lit. Index Nos. AY/15.0, AY/16.0 and AY/17.0.



**Spoolmatic® 30A Spool Gun**  
#130 831  
Air-cooled, 200-amp, 0.45-kg spool gun for

aluminum MIG. See Lit. Index No. M/1.73.

**WC-24 Control** #137 549

Use with Spoolmatic 30A.

**XR™ Wire Feeders and Guns**

Push-pull system designed to handle difficult-to-feed soft alloy wires such as aluminum. See Lit. Index No. M/1.7, M/1.71, and M/1.73.

## TIG (GTAW) Welding



**Dynasty® 200 Series**  
For premium portable AC/DC TIG arc quality. See Lit. Index No. AD/4.8.



**HF-251 Series**  
#042 388  
HF-251D-1, 115 VAC  
#042 387  
HF-251D-2, 230 VAC  
High-frequency arc starter and stabilizer.

See Accessory Lit. Index No. AY/5.0.

## Plasma Cutting



*Spectrum 375 X-TREME and 625 X-TREME shown.*

**Spectrum® 375 X-TREME™** #907 529  
See Lit. Index No. PC/9.2.

**Spectrum® 625 X-TREME™** #907 531  
See Lit. Index No. PC/9.6.

**Spectrum® 875** #907 390-01-1  
See Lit. Index No. PC/9.8.

The Spectrum 375 X-TREME and 625 X-TREME come complete with protective X-CASE™ (not shown).

# Genuine Miller® Accessories (Continued)

## Remote Controls (CC models only)



**RHC-3GD34A Remote Hand Control #041 122**  
Allows for precise adjustment of amperage. Includes 6-m (20-ft.) cord.



Includes 6-m (20 ft.) cord and 14-pin plug.

**RFCS-14 HD Foot Control #194 744**  
Heavy-duty foot control for remote current, voltage and contactor control.



Side-to-side rotary-motion fingertip control fastens to TIG torch using two Velcro® straps. Includes 8-m (26.5 ft.) control cord and 14-pin plug.

**RCC-14 Remote Contactor and Current Control #151 086**



**RCLS-14 Remote Contactor and Current Control #043 688**

Up-and-down rotary-motion fingertip control fastens to TIG torch using two Velcro® straps. Includes 8-m (26.5 ft.) control cord.

## Remote Controls (CC/CV models)



Includes 6-m (20 ft.) cord and 14-pin plug.

**RHC-14 Hand Control #242 211 020**  
Miniature hand control for remote current, voltage and contactor control. Dimensions:

**RMLS-14 #129 337**  
Fingertip momentary- and maintained-contact rocker switch for contactor control. Push forward for maintained contact and back for momentary contact. Includes 8-m (26.5 ft.) cord and 14-pin plug.

**Extension Cables for 14-Pin Remote Controls or 24 VAC Wire Feeders**  
#242 208 025 7.6 m (25 ft.)  
#242 208 050 15.2 m (50 ft.)  
#242 208 080 24.4 m (80 ft.)

## Trailers and Hitches (Note: Trailers are shipped unassembled.)



**4 West Four-Wheel Steerable Off-Road Trailer #042 801**  
A heavy-duty 1166-kg (2570 lb.) capacity trailer designed for use in mines, quarries, and other rough terrain. Has narrow 6.7-m (22 ft.) turning radius. Includes 76-mm (3 in.) lunette eye, universal hitch and safety chains.



**HWY-224 Trailer #043 805** For highway use.

**OFR-224 Trailer #043 802** For off-road use.  
A 1202-kg (2650 lb.) capacity trailer. Welded steel tubing frame, heavy-duty axle with roller bearing hubs and leaf-spring suspension. Includes jack stand and 50-mm (2 in.) ball hitch. *HWY-224 also includes fenders and lights.*

**Cable Tree #043 826**  
Provides an area to conveniently wrap weld cables and extension cords.



**Dual Hitch #300 831**  
50-mm (2 in.) ball hitch and 76-mm (3 in.) lunette eye in one reversible assembly.

## Mounting Specifications

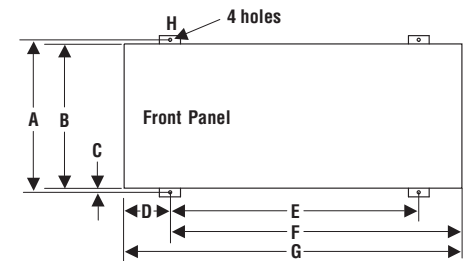

- A. 757 mm (29.812 in.)
- B. 699 mm (27.5 in.)
- C. 25 mm (1 in.)
- D. 244 mm (9.625 in.)\*
- E. 1181 mm (46.5 in.)\*
- F. 1422 mm (56 in.)\*
- G. 1654 mm (65.125 in.)
- H. 14 mm (.562 in.) diameter

**Height:** 1270 mm (50 in.) (to top of exhaust)  
**Width:** 724 mm (28.5 in.)  
(mounting brackets turned in)  
781 mm (30.75 in.)  
(mounting brackets turned out)  
**Depth:** 1654 mm (65.125 in.)

\*With mounting brackets in center position.  
Dimensions vary with location of mounting brackets.

## Trailer Specifications (Subject to change without notice.)

Model	Gross Axle Weight Rating	Gross Vehicle Weight Rating	Net Payload	Height of Bed	Road Clearance	Track (Center to center of tires)	Standard Tires (Standard rating or P-size rating)	Dimensions	Net Weight
4 West	907 kg/axle (2000 lb./axle)	1361 kg (3000 lb.)	1166 kg (2570 lb.)	540 mm (21.25 in.)	203 mm (8 in.)	1403 mm (55.25 in.)	B78-13	Length: 2311 mm (91 in.)* Width: 1556 mm (61.25 in.)	195 kg (430 lb.)
HWY-224 OFR-224	1588 kg (3500 lb.)	1343 kg (2960 lb.)	1202 kg (2650 lb.)	470 mm (18.5 in.)	191 mm (7.5 in.)	1321 mm (52 in.)	B78-13	Length: 2667 mm (105 in.) Width: HWY-1511 mm (59.5 in.)** OFR-1484 mm (58.437 in.)	145 kg (320 lb.)

\*Does not include tongue. \*\*Width at outside of fenders.

# Ordering Information

Equipment and Factory Options	Stock No.	Description	Qty.	Price
<b>Big Blue® 500 X CC</b>	#907 185 #907 187 #907 187-02-1	Deutz D2011L03i with Engine Gauges and Dry Battery Perkins 404D.22 with Engine Gauges and Dry Battery Perkins 404D.22 with Engine Gauges and Dry Battery, Weld Meters and Polarity Switch		
<b>Big Blue® 500 X CC/CV</b>	#907 184 #907 186 #907 186-02-1	Deutz D2011L03i with Engine Gauges and Dry Battery Perkins 404D.22 with Engine Gauges and Dry Battery Perkins 404D.22 with Engine Gauges and Dry Battery, Weld Meters and Polarity Switch		
<b>Big Blue® 600 X CC</b>	#907 193 #907 189 #907 189-01-2	Deutz D2011L04i with Engine Gauges and Dry Battery Deutz D912L03 with Engine Gauges and Dry Battery Deutz D912L03 with Engine Gauges and Wet Battery		
<b>Big Blue® 600 X CC/CV</b>	#907 192 #907 188	Deutz D2011L04i with Engine Gauges and Dry Battery Deutz D912L03 with Engine Gauges and Dry Battery		
<b>Field Accessories</b>				
Weld Ammeter and Voltmeter Kit	#195 131	For all models. Analog welding meters		
Polarity Reversing Switch Kit	#043 942 #195 095	For all models. DC polarity switch For all models. AC/DC polarity switch		
Battery Voltmeter	#195 454	For all models. Analog		
Cold Weather Starting Aid Kit	#195 056 #195 307 #195 086	Perkins. 120 volt block heater Deutz D2011L03i and D2011L04i. 12 volt intake manifold heater Deutz D2011L03i and D2011L04i. 120 volt oil pan heater		
International Plug	#255 416	1-phase, 240 V, 16 A		
Engine Filter Kit	#246 988 #246 989 #246 985	Deutz D2011. Includes air, oil and fuel filters Deutz D912. Includes air, oil and fuel filters Perkins 404. Includes air, oil and fuel filters		
Spark Arrestor Muffler Kit	#195 012	For all models. Horizontal externally mounted		
Lockable Flame Arrestor Fuel Cap	#043 947	For all models. Padlock not included		
Vandalism Lockout Kit	#195 118	For all models. Lockable front control panel and engine compartment		
Cable Holder	#043 946	For all models. Stores up to 61 m (200 ft.) of 2/0 weld cable		
Protective Cover	#194 683	For all models. <b>Will not work with cable holder accessory</b>		
<b>Stick Welding Leads</b>		See page 6		
<b>MIG/Flux-Cored Welding</b>				
SuitCase® X-TREME™ 8VS and 12VS	#300 656/#300 659	See Lit. Index No. M/6.41		
SuitCase® 8RC and 12RC	#300 660/#300 663	See Lit. Index No. M/6.5		
MIG (GMAW)/Flux-Cored (FCAW) Guns		See Lit. Index Nos. AY/15.0, AY/16.0 and AY/17.0		
Spoolmatic® 30A Spool Gun	#130 831	Requires WC-24 Control. See Lit. Index No. M/1.73		
WC-24 Control	#137 549	See Lit. Index No. M/1.5		
XR™ Wire Feeder Control and Guns		See Lit. Index No. M/1.7, M/1.71, and M/1.73		
<b>TIG Welding</b>				
Dynasty® 200 Series		See Lit. Index No. AD/4.8		
High Frequency Arc Starters		See Lit. Index No. AY/5.0		
<b>Plasma Cutting</b>	See page 6			
<b>Remote Controls</b>	See page 7			
<b>Trailers and Hitches</b>				
4 West Four-Wheel Steerable Trailer	#042 801	Trailer with lunette eye, universal hitch and safety chains. For off-road use		
HWY-224 Trailer	#043 805	Trailer with lights, fenders and 50-mm (2 in.) ball hitch. For highway use		
OFR-224 Trailer	#043 802	Trailer with 50-mm (2 in.) ball hitch. For off-road use		
Cable Tree	#043 826	Trailer mounted cable holder for HWY-224 or OFR-224		
Dual Hitch	#300 831	Combination 50-mm (2 in.) ball hitch and 76-mm (3 in.) lunette eye in one reversible assembly. For HWY-224 or OFR-224		

Date:

Total Quoted Price:

Distributed by:

